

DEVKO PLASMA TABLE 4x8
Assembly Instructions

Step 1

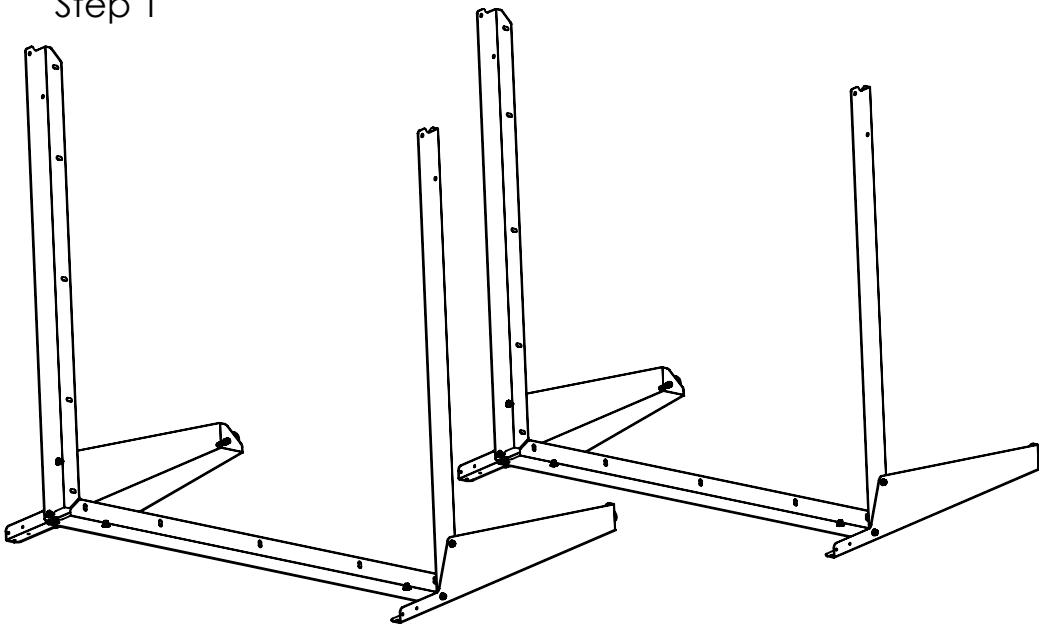

Assembly 2 as shown with sides pointed up and legs on the floor, leave hardware loose, finger tight only! Tighten all hardware on Step 8

Step 2

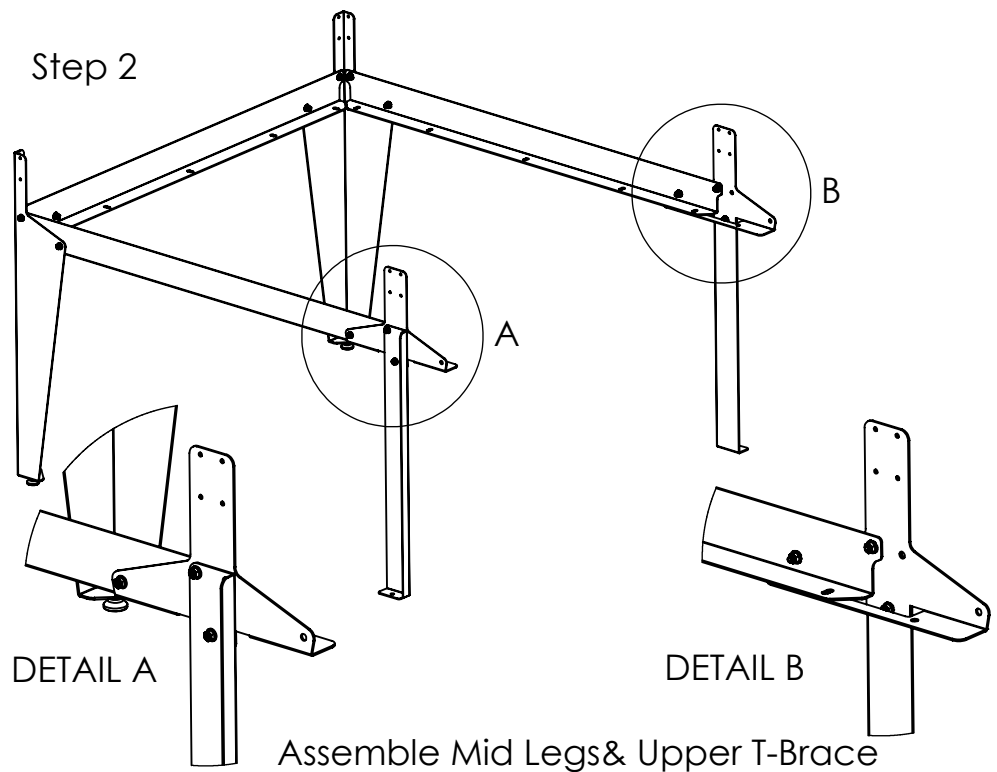

DETAIL A

DETAIL B

Assemble Mid Legs & Upper T-Brace

Step 3

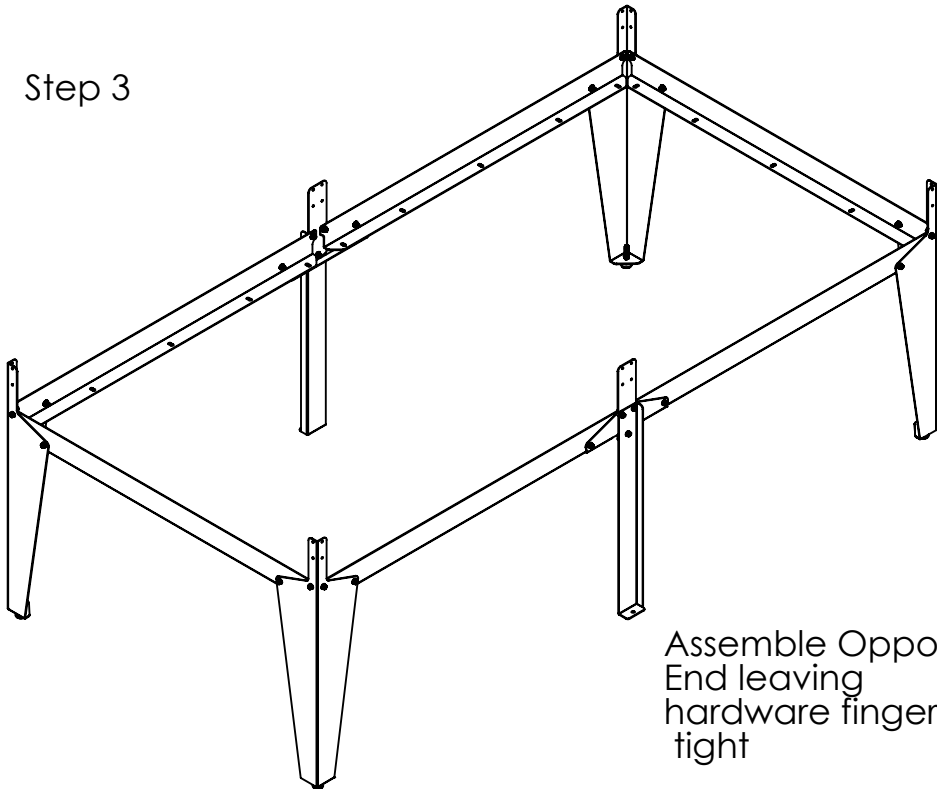

Assemble Opposite End leaving hardware finger tight

Step 4

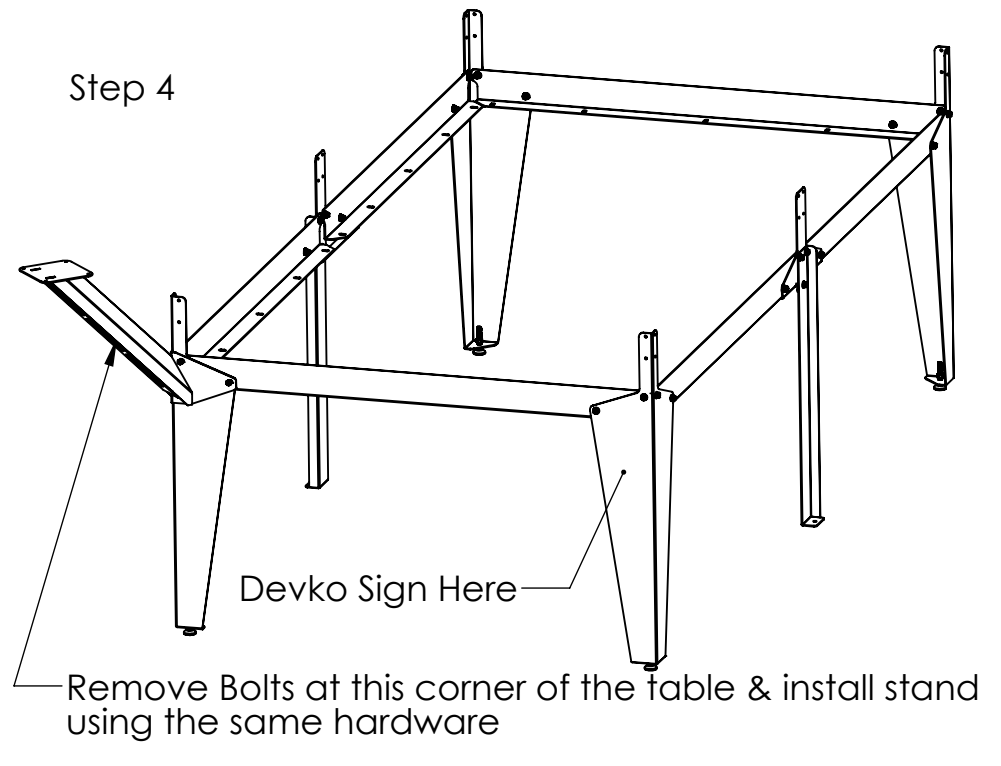

Devko Sign Here

Remove Bolts at this corner of the table & install stand using the same hardware

Step 5

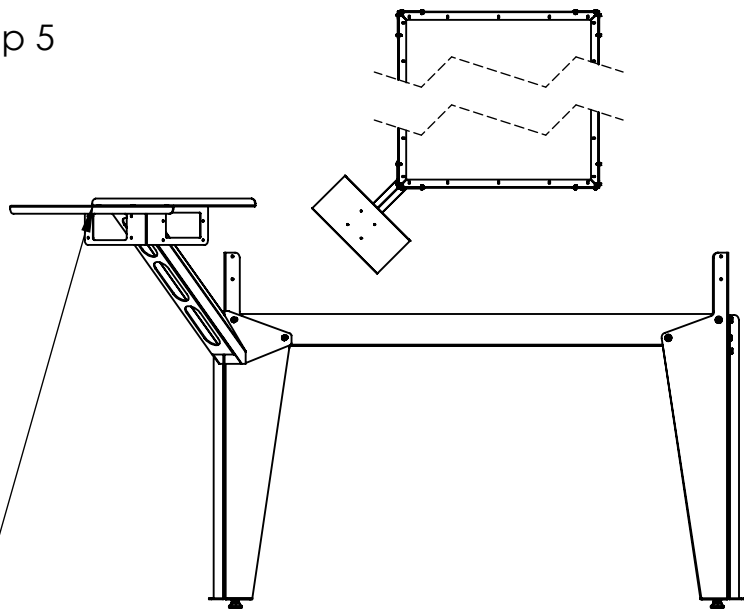

Install Desk Top using 10-32x5/8 Button Head Capscrews

Step 6

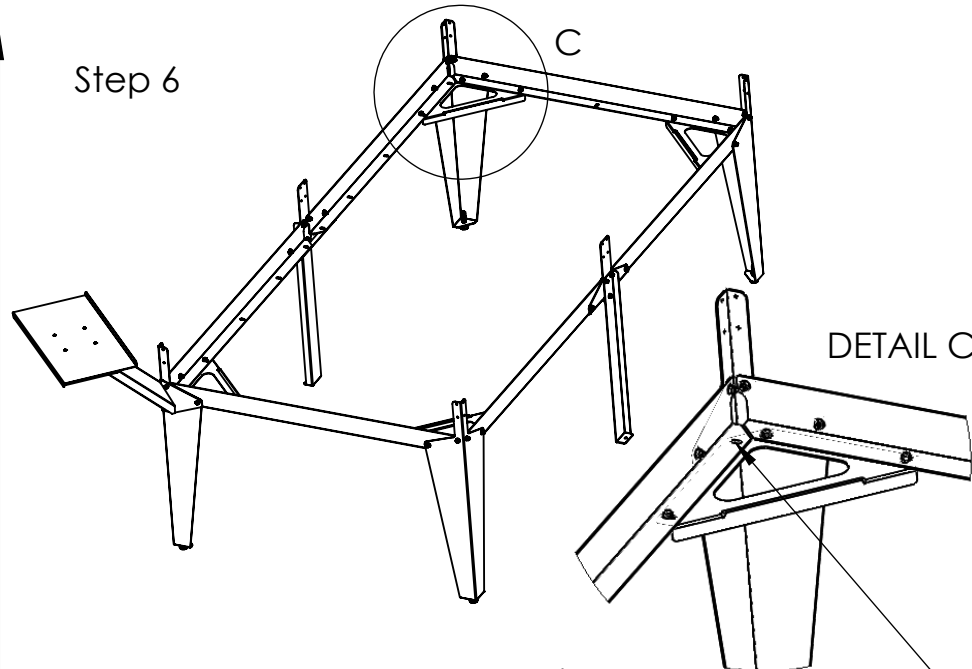

Install Corner Gussets, leave this bolt out for the slat crossmember

Step 7

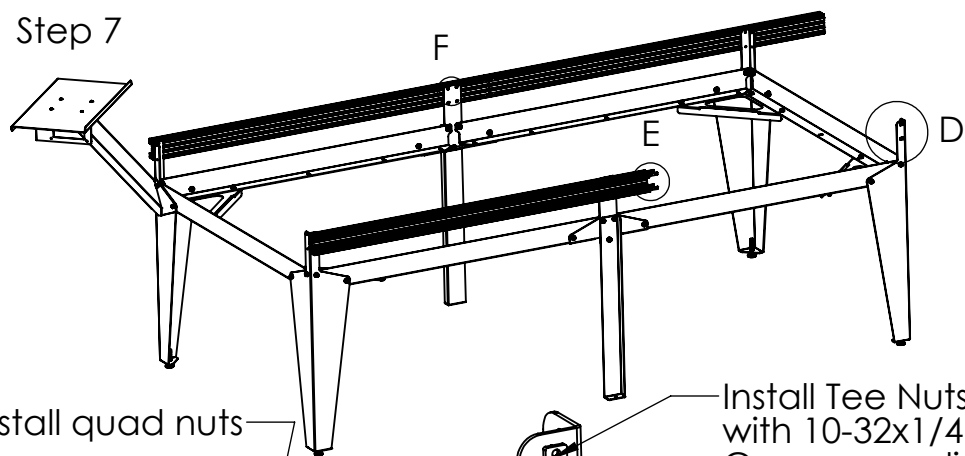

Install quad nuts

Install Tee Nuts with 10-32x1/4 Capscrews, slide rails on & Tighten

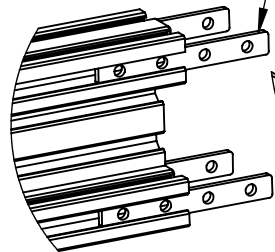

DETAIL E

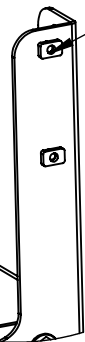

DETAIL D

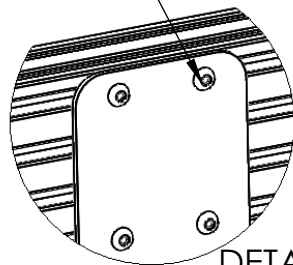

DETAIL F

Step 8

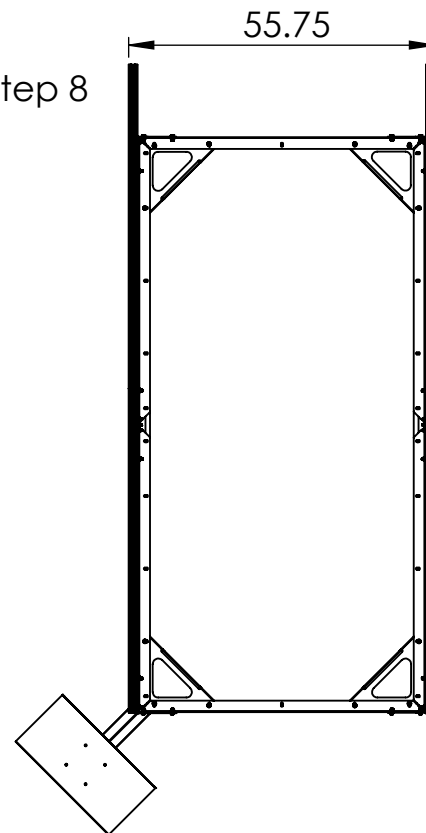

Outer Rail distance must be 55.75" to ensure proper table operation & tighten all hardware

Step 9

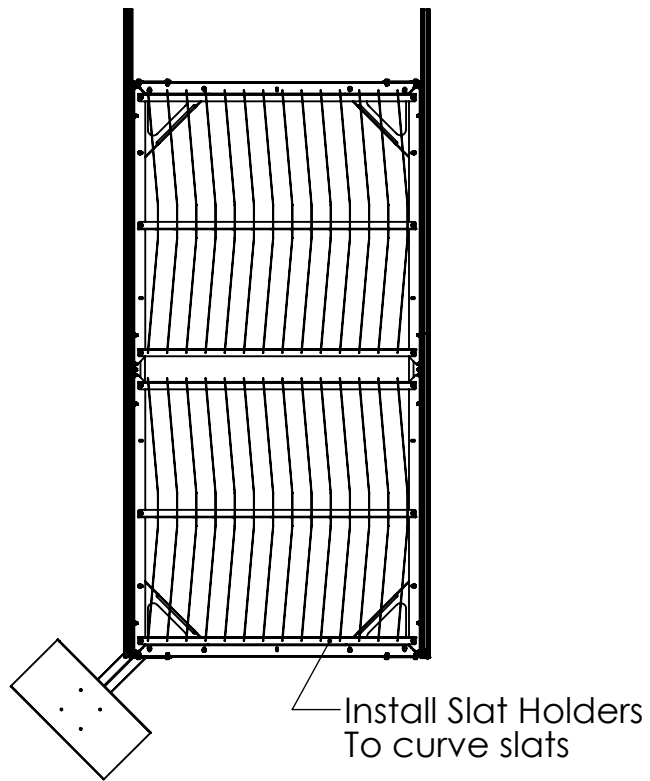

Step 10



Slide Gantry onto rails, recheck measurement of 55.75, rail to rail outside, & along the rails to ensure smooth operation

Step 11

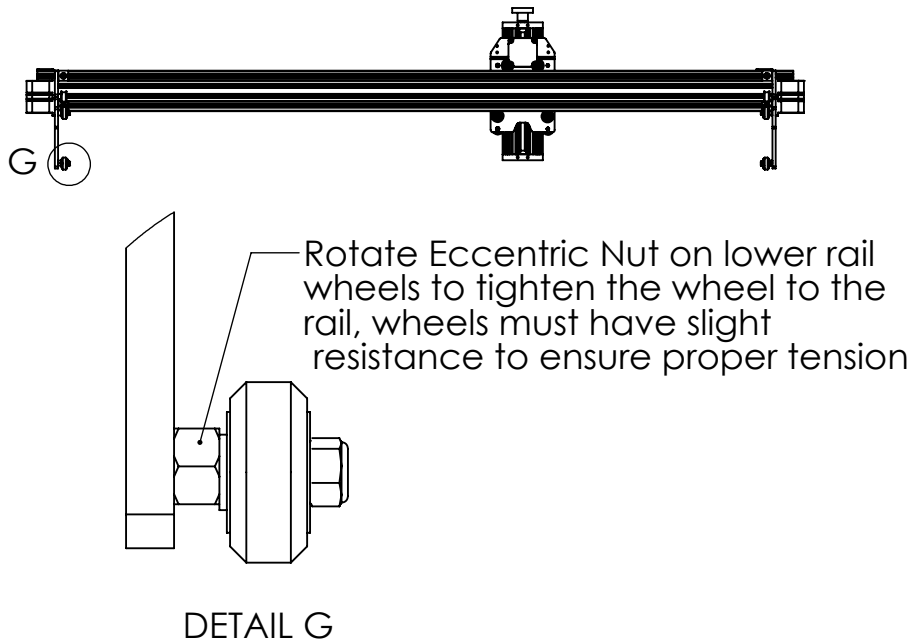

Step 12

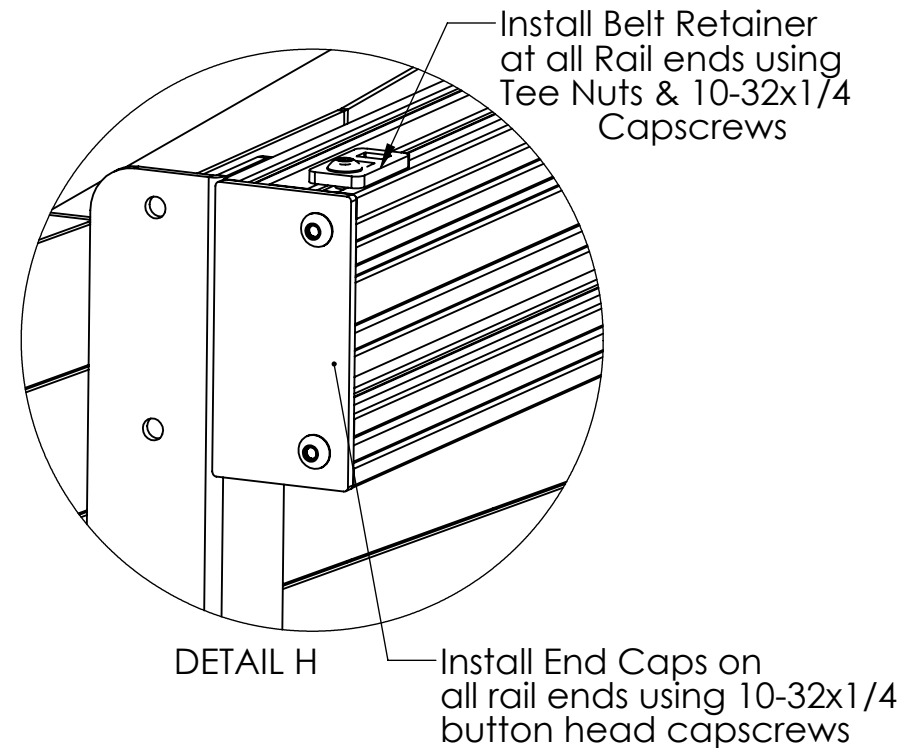

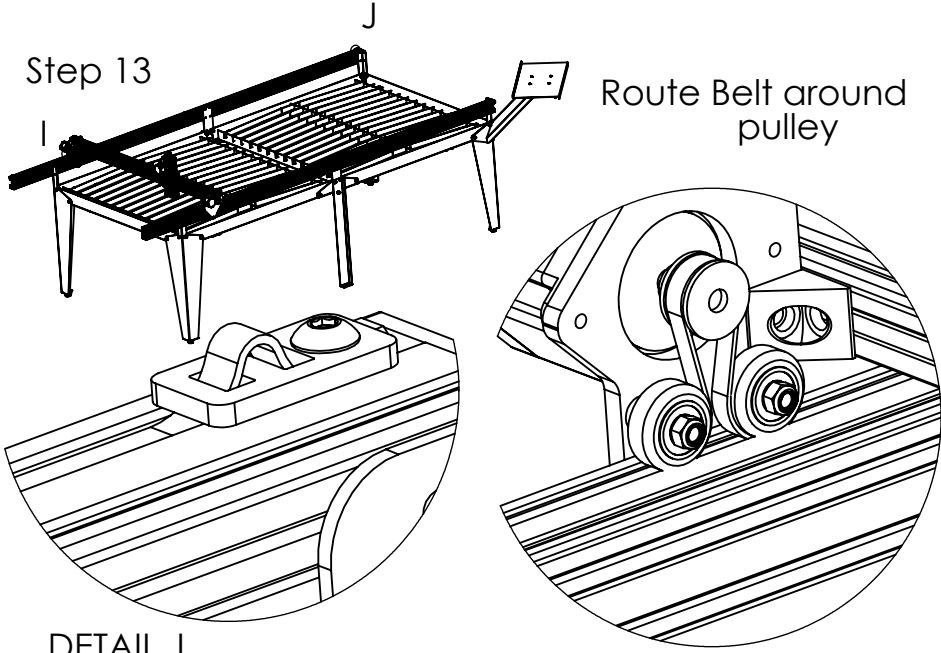

Step 13

Route Belt around pulley

DETAIL J
Thread belt thru retainers & tighten belt with to achieve a fair bit of tension

DETAIL I

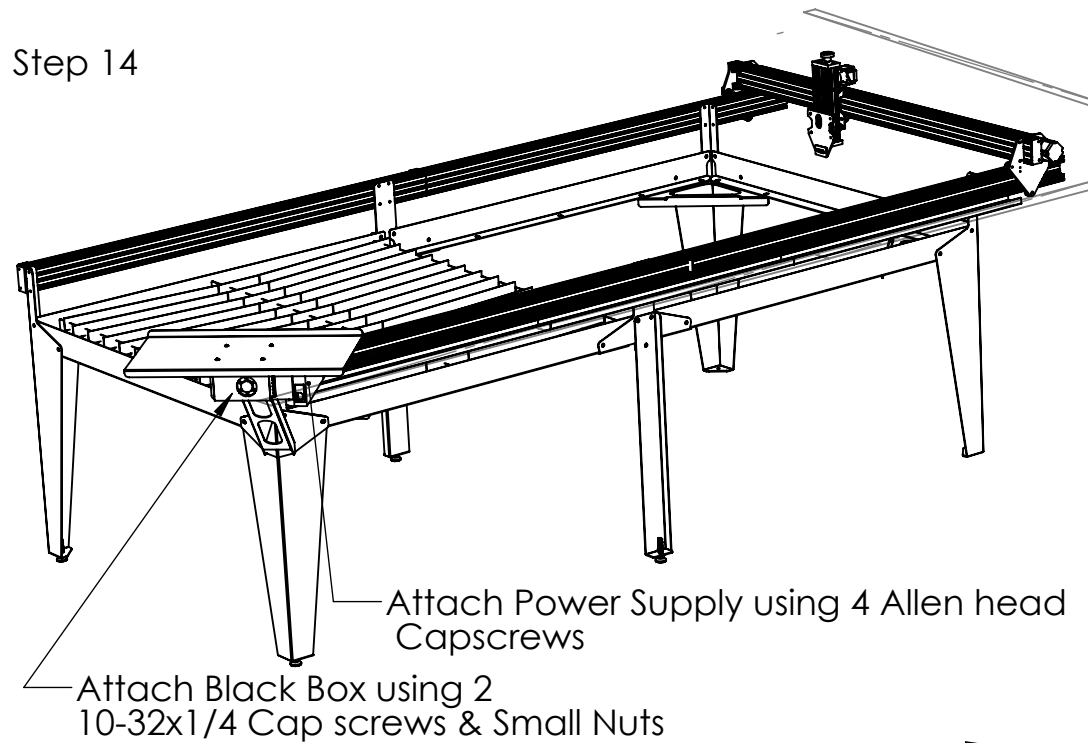

Step 14

Attach Power Supply using 4 Allen head Capscrews

Attach Black Box using 2 10-32x1/4 Cap screws & Small Nuts

Step 15

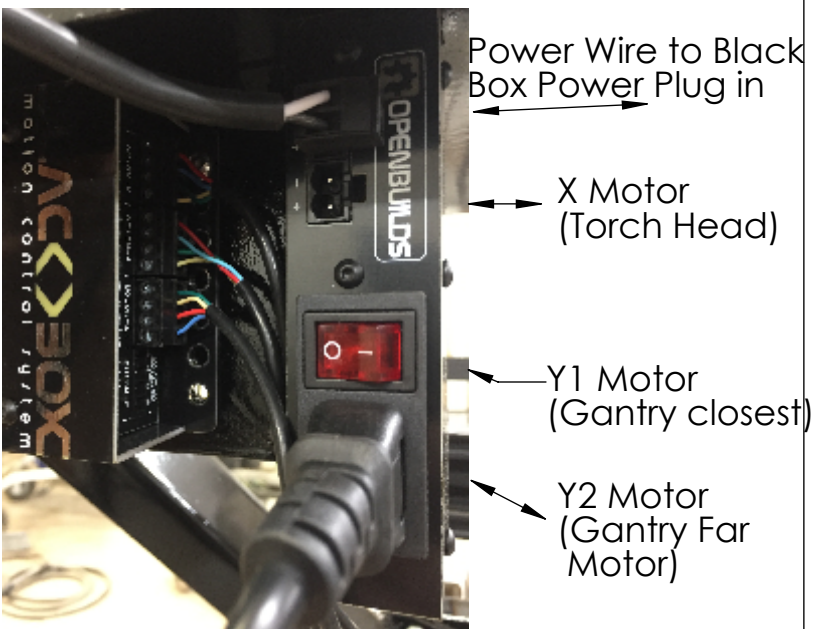

Power Wire to Black Box Power Plug in

X Motor (Torch Head)

Y1 Motor (Gantry closest)

Y2 Motor (Gantry Far Motor)

Connect Wire as Shown, Y2 has a different color combination to account for the direction change from Y1
When connecting at the motors, match wire color to color on all motors

Step 16

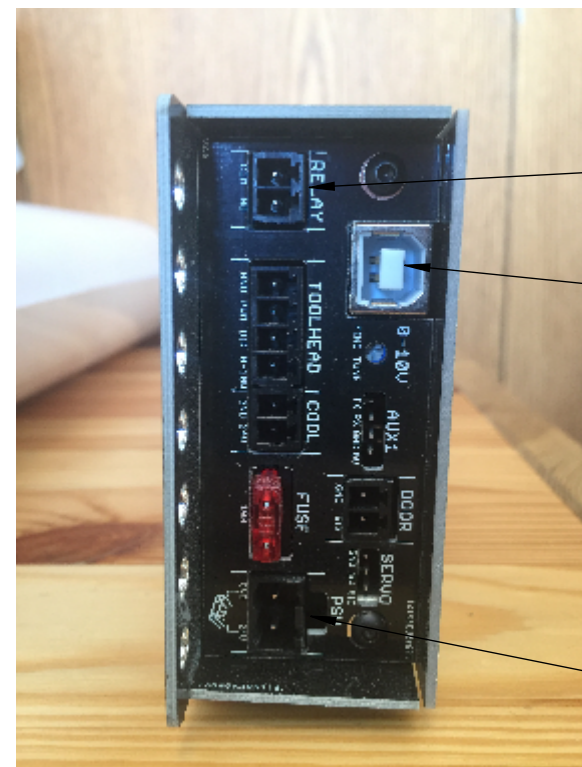

Trigger Wire to Plasma: Polarity not important

USB to Computer

Power from power supply: polarity important